

Canon

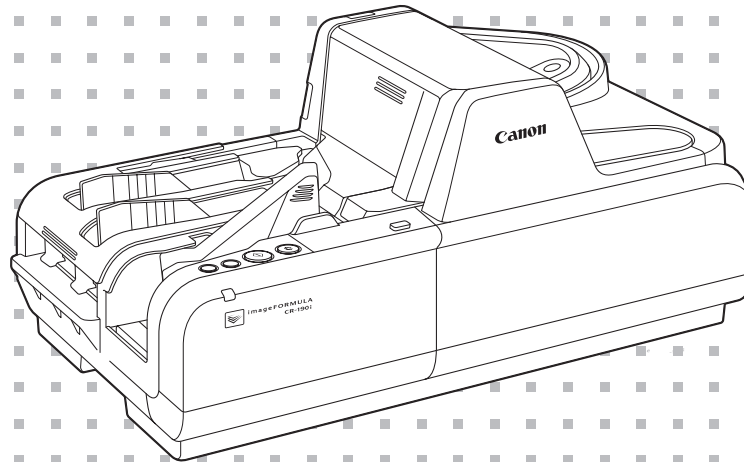

imageFORMULA CR-190i

Installation Guide



◆ Please read this manual before operating this scanner.

READ CAREFULLY BEFORE OPENING THE SEALED DISK PACKAGE

CANON SOFTWARE LICENSE AGREEMENT

IMPORTANT-READ THIS AGREEMENT BEFORE OPENING THE SEALED DISK PACKAGE! BY OPENING THE SEALED DISK PACKAGE, YOU ARE DEEMED TO AGREE TO BE BOUND BY THIS AGREEMENT.

This legal document is a license agreement between you and CANON ELECTRONICS INC. ("Canon"). BY OPENING THE SEALED DISK PACKAGE, YOU ARE DEEMED TO AGREE TO BE BOUND BY THE TERMS OF THIS AGREEMENT. IF YOU DO NOT AGREE TO THE TERMS OF THIS AGREEMENT, DO NOT OPEN THE SEALED DISK PACKAGE AND PROMPTLY RETURN THE CANON SCANNER, THE DISK PACKAGE CONTAINING SCANNER DRIVER SOFTWARE PROGRAMS AND/OR SCANNER UTILITY SOFTWARE PROGRAM PROPRIETARY TO CANON OR ITS LICENSOR (THE "SOFTWARE") AND THE ACCOMPANYING DOCUMENTATION AND OTHER ITEMS TO THE PLACE WHERE YOU OBTAINED THEM FOR A REFUND BEFORE THEY ARE USED OR OPENED OR UNPACKED.

In consideration of the right to use the SOFTWARE, you agree to abide by the terms and conditions of this Agreement.

1. GRANT OF LICENSE: Canon grants you the personal, non-exclusive right to use the SOFTWARE only on a single computer. You may physically transfer the SOFTWARE from one computer to another provided that the SOFTWARE is used on only one computer at any time. You shall not assign, sublicense, sell, rent, lease, loan, convey or transfer to any third party, or send or bring the SOFTWARE out of the country where you originally obtain it to other countries without required authorization of applicable governments, or copy, duplicate, translate or convert to another programming language the SOFTWARE or accompanying documentation, except as expressly provided herein. Except as expressly permitted under the applicable law, you shall not alter, modify, disassemble, decompile or otherwise reverse engineer the SOFTWARE or accompanying documentation and you also shall not have any third party do so.

2. BACK-UP COPY: You may make one copy of the SOFTWARE solely for a back-up purpose or copy the SOFTWARE onto the permanent storage device (e.g. a hard disk) of your computer and retain the original for a back-up purpose. Except as expressly permitted under the applicable law, any other copying of the SOFTWARE is a violation of this Agreement. You must reproduce and include the copyright notice on the back-up copy.

3. SUPPORT AND UPDATE: Canon, Canon's affiliate, their distributor or dealer is not responsible for maintaining or helping you to use the SOFTWARE. No updates, fixes or support will be made available for the SOFTWARE.

4. LIMITED WARRANTY AND DISCLAIMER OF INDEMNITY: Canon, Canon's affiliate, their distributor or dealer will not guarantee uninterrupted service, or absence or correction of errors. Therefore, the SOFTWARE is licensed on an "AS IS" basis without warranty of any kind. The diskette on which the SOFTWARE is recorded is warranted against defective material or workmanship under normal use for a period of ninety (90) days from the date you purchased the same as evidenced by a receipt or otherwise. The limited warranty does not apply if the failure of the diskette resulted from accident, abuse or misapplication of the SOFTWARE and shall not extend to anyone other than the original user of the SOFTWARE. CANON, CANON'S AFFILIATE, THEIR DISTRIBUTOR OR DEALER DISCLAIMS ALL IMPLIED WARRANTIES, INCLUDING ANY WARRANTY OF MERCHANTABILITY OR FITNESS FOR A PARTICULAR PURPOSE, WITH RESPECT TO THE SOFTWARE OR ACCOMPANYING DOCUMENTATION. NEITHER CANON, CANON'S AFFILIATE, THEIR DISTRIBUTOR NOR DEALER IS LIABLE FOR ANY LOSS OR DAMAGE INCLUDING CONSEQUENTIAL OR INCIDENTAL LOSS OR DAMAGE SUCH AS LOSS OF PROFITS, EXPENSE OR INCONVENIENCE, WHATSOEVER CAUSED BY OR ARISING OUT OF THE SOFTWARE, ACCOMPANYING DOCUMENTATION OR THE USE THEREOF. CANON, CANON'S AFFILIATE, THEIR DISTRIBUTOR OR DEALER SHALL HAVE NO OBLIGATION TO INDEMNIFY YOU AGAINST ANY CLAIM OR SUIT BROUGHT BY A THIRD PARTY ALLEGING THAT THE SOFTWARE, ACCOMPANYING DOCUMENTATION OR THE USE THEREOF INFRINGES ANY INTELLECTUAL PROPERTY OF SUCH THIRD PARTY.

THE ABOVE IS CANON'S ENTIRE LIABILITY AND YOUR EXCLUSIVE REMEDY IN CONNECTION WITH THE SOFTWARE AND ACCOMPANYING DOCUMENTATION.

5. TERM: This Agreement is effective upon opening the sealed disk package and remains in effect until terminated. You may terminate this Agreement by destroying the SOFTWARE and any copy thereof. This Agreement will also terminate if you fail to comply with any of the terms of this Agreement. In addition to Canon enforcing its respective legal rights, you must then promptly destroy the SOFTWARE and any copy thereof.

6. U.S. GOVERNMENT RESTRICTED RIGHTS NOTICE: The SOFTWARE is provided with RESTRICTED RIGHTS. Use, duplication or disclosure is subject to restrictions as set forth in either subparagraph (c) (1) (ii) of the Rights in Technical Data and Computer Software clause at DFARS 252.227-7013 or subparagraph (c) (1) and (2) of the Commercial Computer Software Restricted Rights Clause at FAR 52.227-19, as applicable.

7. SEVERABILITY: In the event that provision of this Agreement is declared or found to be illegal by any court or tribunal of competent jurisdiction, such provision shall be null and void with respect to the jurisdiction of that court or tribunal and all the remaining provisions of this Agreement shall remain in full force and effect.

8. ACKNOWLEDGEMENT: BY OPENING THE SEALED DISK PACKAGE, YOU ACKNOWLEDGE THAT YOU HAVE READ THIS AGREEMENT, UNDERSTOOD IT, AND AGREE TO BE BOUND BY ITS TERMS AND CONDITIONS. YOU ALSO AGREE THAT THIS AGREEMENT IS THE COMPLETE AND EXCLUSIVE STATEMENT OF AGREEMENT BETWEEN YOU AND CANON CONCERNING THE SUBJECT MATTER HEREOF AND SUPERSEDES ALL PROPOSALS OR PRIOR AGREEMENTS, VERBAL OR WRITTEN, AND ANY OTHER COMMUNICATIONS BETWEEN YOU AND CANON RELATING TO THE SUBJECT MATTER HEREOF. NO AMENDMENT TO THIS AGREEMENT SHALL BE EFFECTIVE UNLESS SIGNED BY A DULY AUTHORIZED REPRESENTATIVE OF CANON.

Should you have any questions concerning this Agreement, or if you desire to contact Canon for any reason, please write to Canon's local affiliate.

■ FCC REGULATIONS (For 120V model)

Check Reader, Model M111021

This device complies with Part 15 of the FCC Rules. Operation is subject to the following two conditions:

(1) This device may not cause harmful interference, and (2) this device must accept any interference received, including interference that may cause undesired operation.

Note: This equipment has been tested and found to comply with the limits for a Class B digital device, pursuant to Part 15 of the FCC Rules. These limits are designed to provide reasonable protection against harmful interference in a residential installation. This equipment generates, uses, and can radiate radio frequency energy and, if not installed and used in accordance with the instructions, may cause harmful interference to radio communications. However, there is no guarantee that interference will not occur in a particular installation. If this equipment does cause harmful interference to radio or television reception, which can be determined by turning the equipment off and on, the user is encouraged to try to correct the interference by one or more of the following measures:

- Reorient or relocate the receiving antenna.
 - Increase the separation between the equipment and receiver.
 - Connect the equipment into an outlet on a circuit different from that to which the receiver is connected.
 - Consult the dealer or an experienced radio/TV technician for help.
- Use of shielded cable is required to comply with class B limits in Subpart B of Part 15 of FCC Rules.

Do not make any changes or modifications to the equipment unless otherwise specified in the manual. If such changes or modifications should be made, you could be required to stop operation of the equipment.

Canon U.S.A. Inc.

One Canon Plaza, Lake Success NY 11042, U.S.A.

Tel. No. (516)328-5000

■ RADIO INTERFERENCE REGULATIONS (For 120V models)

This digital apparatus does not exceed the Class B limits for radio noise emissions from digital apparatus as set out in the interference-causing equipment standard entitled "Digital Apparatus", ICES-003 of the Industry Canada.

■ RÈGLEMENT SUR LE BROUILLAGE RADIOÉLECTRIQUE (For 120V models)

Cet appareil numérique respecte les limites de bruits radioélectriques applicables aux appareils numériques de Classe B prescrites dans la norme sur le matériel brouilleur: "Appareils Numériques", NMB-003 édictée par l'Industrie Canada.

■ International ENERGY STAR® Office Equipment Program

As an ENERGY STAR® Partner, CANON ELECTRONICS INC. has determined that this machine meets the ENERGY STAR® Program guidelines for energy efficiency.

The International ENERGY STAR® Office Equipment Program is an international program that promotes energy saving through the use of computers and other office equipment.

The program backs the development and dissemination of products with functions that effectively reduce energy consumption. It is an open system in which business proprietors can participate voluntarily. The targeted products are office equipment, such as computers, monitors, printers, fax, machine, copiers, and scanners. The standards and logos are uniform among participating nations.



■ European Union (and EEA) only.



This symbol indicates that this product is not to be disposed of with your household waste, according to the WEEE Directive (2002/96/EC) and your national law. This product should be handed over to a designated collection point, e.g., on an authorized one-for-one basis when you buy a new similar product or to an authorized collection site for recycling waste electrical and electronic equipment (EEE). Improper handling of

this type of waste could have a possible negative impact on the environment and human health due to potentially hazardous substances that are generally associated with EEE. At the same time, your cooperation in the correct disposal of this product will contribute to the effective usage of natural resources. For more information about where you can drop off your waste equipment for recycling, please contact your local city office, waste authority, approved WEEE scheme or your household waste disposal service. For more information regarding return and recycling of WEEE products, please visit www.canon-europe.com/environment. (EEA: Norway, Iceland and Liechtenstein)

■ Für EMVG

Dieses Produkt ist zum Gebrauch im Wohnbereich, Geschäfts-und Gewerbebereich sowie in Kleinbetrieben vorgesehen.

■ Model Names

The following names may be provided for the safety regulations in each sales region of the Check Reader.

CR-190i: Model M111021

■ Trademarks

- Canon and the Canon logo are registered trademarks of Canon Inc. in the United States and may also be trademarks or registered trademarks in other countries.
- imageFORMULA is a trademark of CANON ELECTRONICS INC.
- Microsoft, Windows, Windows Vista, and Windows 7 are registered trademarks or trademarks of Microsoft Corporation in the United States and other countries.
- Microsoft product screen shot(s) reprinted with permission from Microsoft Corporation.
- Adobe, Acrobat, and Adobe Reader are registered trademarks or trademarks of Adobe Systems Incorporated in the United States and other countries.
- Other product and company names herein are, or may be, the trademarks of their respective owners.
- Ranger is a trademark of Silver Bullet technology, Inc.

■ Copyright

Copyright 2010 by CANON ELECTRONICS INC. All rights reserved.

No part of this publication may be reproduced or transmitted in any form or by any means, electronic or mechanical, including photocopying and recording, or by any information storage or retrieval system without the prior written permission of CANON ELECTRONICS INC.

■ **Disclaimers**

The information in this document is subject to change without notice.

CANON ELECTRONICS INC. MAKES NO WARRANTY OF ANY KIND WITH REGARD TO THIS MATERIAL, EITHER EXPRESS OR IMPLIED, EXCEPT AS PROVIDED HEREIN, INCLUDING WITHOUT LIMITATION, THEREOF, WARRANTIES AS TO MARKETABILITY, MERCHANTABILITY, FITNESS FOR A PARTICULAR PURPOSE OF USE OR NON-INFRINGEMENT. CANON ELECTRONICS INC. SHALL NOT BE LIABLE FOR ANY DIRECT, INCIDENTAL, OR CONSEQUENTIAL DAMAGES OF ANY NATURE, OR LOSSES OR EXPENSES RESULTING FROM THE USE OF THIS MATERIAL.

CANON ELECTRONICS INC. IS NOT LIABLE FOR THE STORAGE AND HANDLING OF DOCUMENTS SCANNED WITH THIS PRODUCT, OR THE STORAGE AND HANDLING OF THE RESULTING SCANNED IMAGE DATA. IF YOU INTEND TO DISCARD THE ORIGINALS OF THE SCANNED DOCUMENTS, YOU ARE RESPONSIBLE FOR INSPECTING THE SCANNED IMAGES AND VERIFYING THAT THE DATA IS INTACT. THE MAXIMUM LIABILITY OF CANON ELECTRONICS INC. UNDER THIS WARRANTY IS LIMITED TO THE PURCHASE PRICE OF THE PRODUCT COVERED BY THE WARRANTY.

INTRODUCTION

Thank you for purchasing the Canon Check Reader CR-190i. Please read this manual thoroughly before using the machine in order to familiarize yourself with its capabilities, and to make the most of its many functions.

Manuals for the CR-190i

The following manuals are provided with the CR-190i. Be sure to read these manuals thoroughly before using the scanner. (The Installation Guide and the Operation & Maintenance Guide are extracted from the Instructions.) Electronic manual is stored as a PDF file on the supplied Setup Disc and requires Adobe Reader to open. (You can download Adobe Reader from the Adobe Web site.)

Installation Guide (Supplied with the scanner/Electronic Manual): This Manual

Describes the procedure for setting up the CR-190i for scanning. Set up the CR-190i in accordance with the Installation Guide. For details on the CR-190i, refer to the *Instructions* (electronic manual).

Operation & Maintenance Guide (Supplied with the scanner/Electronic Manual)

Describes the basic operations for using the CR-190i, troubleshooting, and maintenance. For details on the settings of the CR-190i, refer to the *Instructions* (electronic manual).

Instructions (Electronic Manual)

Describes how to use the scanner, and includes instructions for configuring the scanner settings, as well as handling, maintenance, and troubleshooting information.

Symbols Used in This Manual

The following symbols are used in this manual to explain procedures, restrictions, handling precautions, and instructions that should be observed for safety.

WARNING

Indicates a warning concerning operations that may lead to death or injury to persons if not performed correctly. To use the machine safely, always pay attention to these warnings.

CAUTION

Indicates a caution concerning operations that may lead to injury to persons, or damage to property if not performed correctly. To use the machine safely, always pay attention to these cautions.

IMPORTANT

Indicates operational requirements and restrictions. Be sure to read these items carefully to operate the machine correctly, and avoid damaging the machine.

NOTE

Indicates a clarification of an operation, or contains additional explanations for a procedure. Reading these notes is highly recommended.

Table of Contents

INTRODUCTION	3
Manuals for the CR-190i	3
Symbols Used in This Manual	3
Important Safety Instructions	5
Handling	5
Installation Location	6
Power Supply	6
Moving the Scanner	6
Packaging: What Is in the Box?	7
Preparation Before Use	8
Setting Up the Scanner	8
Checking Your Operating Environment	9
Installing the Scanning Utility	9
Connecting the Scanner to a Computer	10
USB Connections	10
Connecting the Power Cord	11
Turning ON and OFF the Power	11
Turning ON the Power	11
Turning OFF the Power	12
Preparing the Ink Cartridge	13
About the Ink Cartridge	13
Setting the Ink Cartridge and Adjusting the Print Position ...	13
Document Feeding and Scanning	15
Index	16

Important Safety Instructions

Handling

WARNING

- Never install and operate the scanner near flammable substances, such as alcohol, paint thinner, benzene, or any other type of volatile solution.
- Never damage or modify the power cord, and never place heavy objects on the power cord.
- Always make sure that your hands are dry when you are handling the power cord or power plug. Never grasp the power plug when your hands are wet.
- Never plug the scanner into a multiplug power strip.
- Never bundle, wrap, or tie the power cord around itself or another object. Connect the power plug securely into the power outlet.
- Use only the power cord and power plug provided with the scanner.
- Never attempt to disassemble or modify the scanner.
- Never use flammable aerosol products near the scanner.
- Before you clean the scanner, turn the power OFF and disconnect the power cord from the power outlet.
- To clean the scanner's exterior, use a firmly wrung cloth, moistened slightly with water or mild detergent. Never use any type of volatile solution, such as alcohol, benzene or paint thinner.
- If you hear strange sounds, detect smoke or abnormal heat, sense vibration, or smell odd odors around the scanner, turn OFF the power switch immediately and disconnect the power cord from the power outlet. Contact your local authorized Canon dealer or service representative to have the scanner serviced.
- Handle the scanner with care. Avoid shock and vibration to the scanner caused by reckless handling. If you suspect the scanner has been accidentally damaged, turn OFF the power switch immediately and disconnect the power cord from the power outlet. Contact your local authorized Canon dealer or service representative to have the scanner serviced.
- Before you move the scanner, always turn OFF the power and disconnect the power cord from the power outlet.

CAUTION

- To avoid damage to the scanner, never place the scanner on an unstable or vibrating surface. The scanner may tip or fall over, causing injury.
- To avoid overheating and causing a fire, never block the air vents on the back of the scanner.
- Keep all liquids, beverages, or any type of liquid, and clips, staples, necklaces, or other metal objects away from the scanner. If you accidentally spill liquid or drop a metal object into the scanner, turn OFF the power immediately and disconnect the power cord from the power outlet. Contact your local authorized Canon dealer or service representative to have the scanner serviced.
- Never install the scanner in humid or dusty locations. Doing so may cause a fire or electrical shock.
- Never place heavy objects on top of the scanner, as these objects may tip or fall over, and cause injury.
- When you remove the power cord, grip it by the power plug head. Never attempt to disconnect the power cord from the power outlet by pulling on the power cord. Doing so may damage or expose the cord's internal wiring, and cause a fire or electrical shock.
- Keep the area around the power outlet clear of all obstacles so you can disconnect the power cord easily at all times.
- Never spill water or volatile solutions (alcohol, benzene, paint thinner) into the scanner. Doing so may cause a fire or electrical shock.
- When the scanner is not being used for a long period of time, disconnect the power cord from the power outlet.
- Avoid wearing loose fitting clothing, dangling jewelry, long ties, or long hair that could become entangled with moving parts, especially the rollers that feed paper into the scanner. If such objects become entangled, immediately disconnect the power plug from the power outlet to stop the scanner.
- Be careful when you are loading a document or clearing a paper jam. It is possible that the paper edges may cut your fingers.
- Do not open the Maintenance Cover while the scanner is operating. Doing so may result in a malfunction or injury.
- Do not touch the pins and contacts on the scanner's connector with your hands. Doing so may result in a malfunction.
- Do not touch anything except the operation buttons when the jogger is operating or documents are being fed.

Installation Location

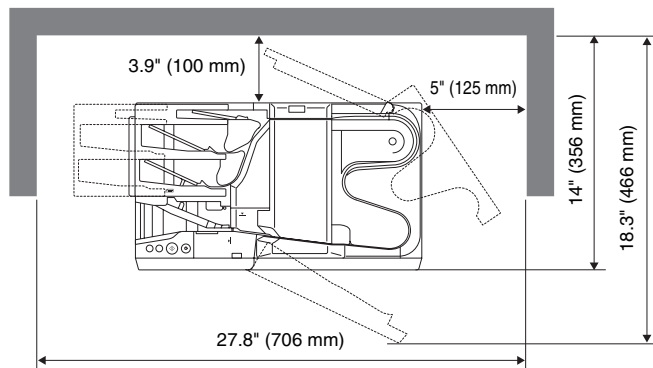

For operation, maintenance, and ventilation, make sure that there is enough space around the scanner, as shown in the illustration above.

Avoid placing the scanner in the following places. It may cause a malfunction and adversely affect the scanner or your computer.

- Places exposed to direct sunlight
If installation in such places is unavoidable, provide a curtain or similar object to shade the scanner.
- Places subject to dust and fumes
Dust and cigarette fumes adversely affect the components inside the scanner.
- Near running water, a heat source, water vapor, or in an area, such as a laboratory exposed to ammonia gas, paint thinner, or other volatile chemicals
- Places subject to excessive vibration and shock
- Places subject to rapid changes in temperature or humidity
Condensation occurring inside the scanner may impair image quality. Place the scanner in a room that is within the following range:
Room temperature: 50°F to 90.5°F (10°C to 32.5°C)
Relative humidity: 20% to 80% RH
Use the recommended operating environment for the ink cartridge when using the imprinter.
- Near electronic equipment or heavy equipment that generates a strong magnetic field, such as a speaker, TV, and radio

Power Supply

- Connect only to a power outlet of the rated voltage and power supply frequency (either 120 V, 60 Hz or 220-240 V, 50/60 Hz, depending on your region).
- Make sure that the scanner is connected to an independent power outlet. Do not plug the scanner into an outlet shared with another device. If you use an extension cord, make sure that the extension cord is rated for the current requirements of the scanner.
- If you are unsure of anything relating to the power supply, contact your local authorized Canon dealer or service representative for further information.
- Never place an object on top of the power cord or step on the power cord.
- Never bundle the power cord or wrap the cord around an object, such as a table leg.
- Do not tug on the power cord. When you remove the power cord, grip it by the power plug head.
- Keep the area around the power outlet free of obstacles.

Moving the Scanner

When you move the CR-190i, hold it firmly with both hands and carry it carefully. Do not hold the scanner by the Eject Stopper. The scanner weighs approximately 18.5 lb (8.4 kg).

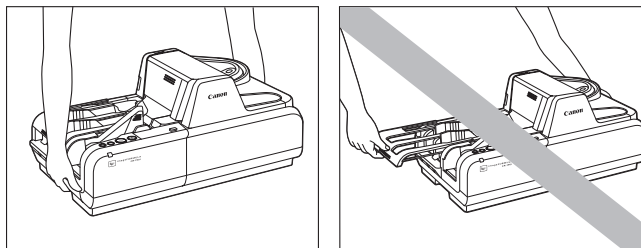

⚠ WARNING

When moving the scanner, be sure to turn OFF the power and remove any cables. If the cables are not removed before moving the scanner, you may damage the plugs or connector by forcibly pulling them out.

Packaging: What Is in the Box?

Make sure that you have everything shown below. Check every item you have removed from the box. If any items are missing, contact your local authorized Canon dealer.

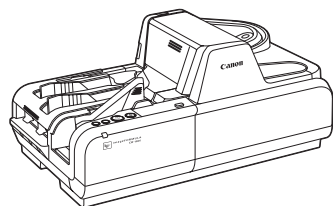

CR-190i



Setup Disc



Power Cord*¹

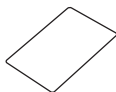

Warranty Card*²

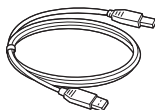

USB Cable

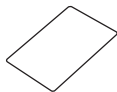

User Registration Card*²

Installation Guide
Operation & Maintenance Guide

*¹ The power cord varies, according to the country of purchase.

*² For the United States and Canada only.

Preparation Before Use

This chapter describes how to prepare the scanner to scan documents.

Setting Up the Scanner

Perform the following steps to set up the CR-190i. Refer to the section for each step for details about that step.

1 Check your operating environment. (See “Checking Your Operating Environment” on p. 9.)



2 Install the software. (See “Installing the Scanning Utility” on p. 9.)

Install the Scanning Utility provided with the CR-190i.



3 Connect the scanner to a computer. (See “Connecting the Scanner to a Computer” on p. 10.)



4 Turn ON the power. (See “Turning ON the Power” on p. 11.)



5 Automatically installing the device driver. (See p. 12.)

The device driver is installed automatically when Windows recognizes the CR-190i.

! IMPORTANT

- To have the device drivers installed automatically when the computer recognizes the CR-190i, the software needs to be installed before the CR-190i is connected to the computer.
- If you connect the computer and turn ON the CR-190i before installing the software, the following wizard screen appears. If this happens, click [Cancel], turn OFF the CR-190i, and then install the software.

The following wizard screen is an example in Windows Vista. When a similar wizard screen appears in Windows XP/7, click [Cancel].

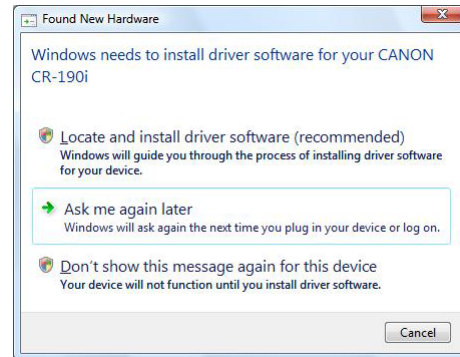

Wizard Screen (Windows Vista)

Checking Your Operating Environment

The following computer system requirements are recommended for using the CR-190i.

Operating Systems:

- Microsoft Windows XP (32bit) SP3 or later
- Microsoft Windows XP (64bit) SP2 or later
- Microsoft Windows Vista (32/64bit) SP1 or later
- Microsoft Windows 7 (32/64bit)

Specifications:

- CPU: Intel Core2 Duo 3.0 GHz or faster
- Memory: 1 GB or more
- USB 2.0 interface

Interface Cable

- Use the cable provided or a Hi-Speed USB 2.0 interface cable to connect to the computer's USB port.

! IMPORTANT

- If you use the USB interface that was provided as standard with your computer:
 - Use the most recently available USB 2.0 driver provided by Microsoft. Contact your local authorized Canon dealer for more detailed information.
 - Not all USB interfaces provided as standard with personal computers are guaranteed. Contact your local authorized Canon dealer for more detailed information.
 - Scanning speeds are slower if your computer's standard USB interface is USB 1.1.
 - You should use the USB cable originally bundled with the scanner or a Hi-Speed USB 2.0 compatible cable.
- If the CPU, memory, interface card, and other specifications do not satisfy the installation requirements, the scanning speed may be greatly reduced and transmission may take longer.
- Even if the computer satisfies the recommended specifications, the scanning speed may vary, depending on the scan settings.

Installing the Scanning Utility

Follow the instructions below to install the Scanning Utility and the dedicated driver.

NOTE

The dedicated scanner driver is installed after the Scanning Utility has been installed.

1 Turn ON your computer, and log on to Windows.

! IMPORTANT

Be sure to log on as the Administrator.

2 Insert the setup disc into the CD-ROM drive.

This manual assumes that "D" is assigned to your CD-ROM drive.

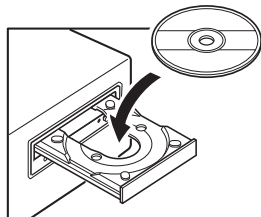

3 Click [Start], and then click [All Programs].

The procedure in Windows XP/7 is different from the ones described in this manual. Refer to the Windows XP/7 "Help and Support Center" to select [Run].

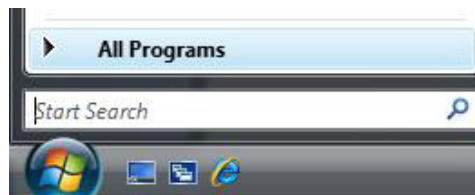

4 Click [Accessories], and then click [Run].

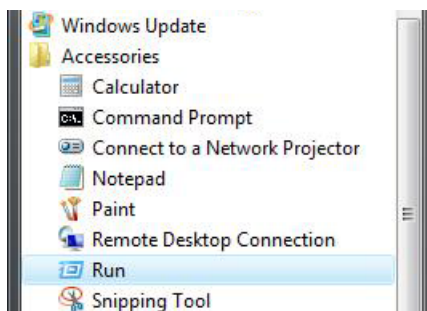

5 Enter “D:\SU190\setup.exe” in the [Open] fields, and then click [OK].

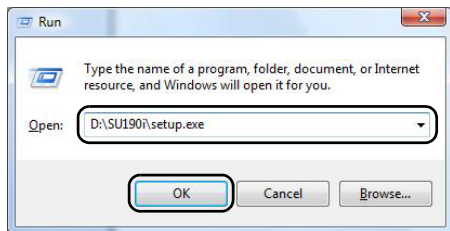

Installation starts.

6 Follow the instructions on the screen to complete the installation.

IMPORTANT

The computer may need to be restarted, after the installation, depending on the operating system. If this is necessary, make sure to restart the computer.

Connecting the Scanner to a Computer

The only way to connect the scanner to your computer is with a USB cable.

CAUTION

- Do not turn OFF the scanner or remove the interface cable when an application is running.
- Turn OFF the computer and the scanner before changing the cable.

USB Connections

Connect the scanner and the computer with the cable provided or a Hi-Speed USB 2.0 cable.

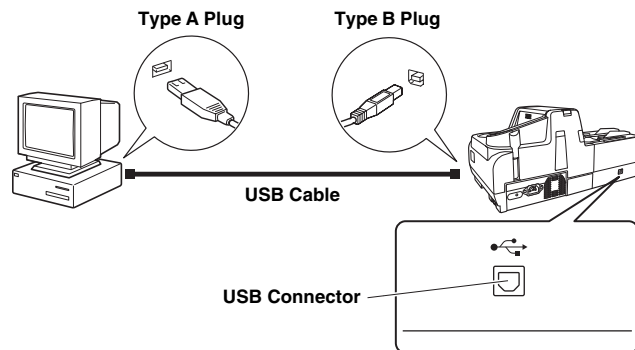

NOTE

Connect the type B plug (square) to the scanner and connect the type A plug (flat) to the USB port on the computer.

Connecting the Power Cord

Connect the power cord.

Make sure to use only the power cord provided with the scanner.

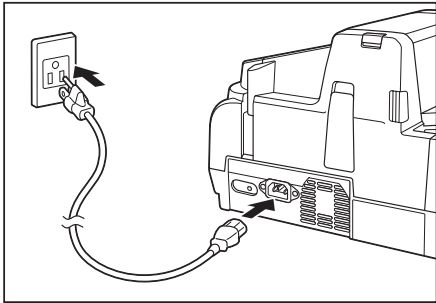

⚠ WARNING

When connecting the power cord, follow these precautions.

Failure to do so may cause a fire or electrical shock.

- Never grasp the power plug when your hands are wet.
- Never plug the scanner into a multiplug power strip.
- Never bundle or tie the power cord around itself or another object. Connect the power plug securely into the power outlet.
- Use only the power cord and power plug provided with the scanner.
- Before you connect the power cord, make sure to turn OFF the power switch.
- Connect only to a power outlet of the rated voltage and power supply frequency (either 120 V, 60 Hz or 220-240 V, 50/60 Hz, depending on your region).
- Do not plug the scanner into a power outlet shared with another device. If you use an extension cord, make sure that the extension cord is rated for the current requirements of the scanner.

Turning ON and OFF the Power

Follow the procedures below to turn the scanner power ON and OFF.

Turning ON the Power

- 1** To turn ON the scanner, press the Power Switch to the “ | ” position.

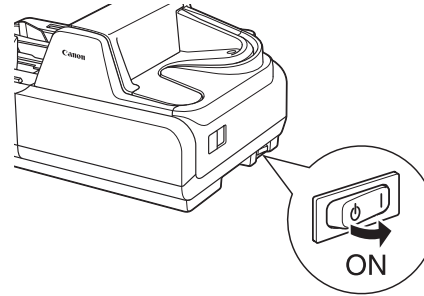

⚠ IMPORTANT

- When you turn ON the power, the power LED lights and remains lit.
- If the scanner does not work, or the power LED continues to flash, there is a problem with the scanner. Turn OFF the power, and contact your local authorized Canon dealer or service representative to have the scanner serviced.

⚠ WARNING

If you hear strange sounds, detect smoke or abnormal heat, sense a vibration, or smell odd odors around the scanner, turn OFF the power immediately and disconnect the power cord from the power outlet. Contact your local authorized Canon dealer or service representative to have the scanner serviced.

- 2** Turn ON your computer.

3 Windows recognizes the CR-190i as new hardware, and installation starts automatically.



(Windows Vista)

NOTE

The CR-190i will be registered as “CANON CR-190i USB” in the Imaging Device directory.

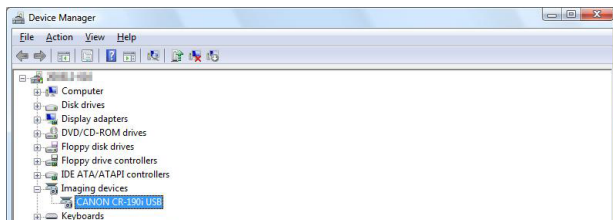

Turning OFF the Power

- 1 Turn OFF your computer.
- 2 To turn OFF the scanner, press the Power Switch to the “” position.

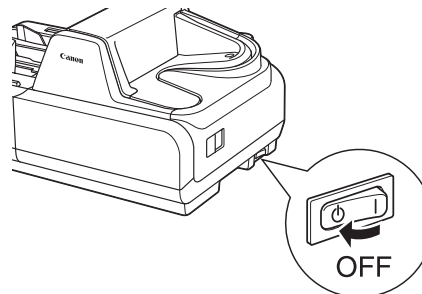

CAUTION

- Wait at least 10 seconds before turning the scanner back ON.
- For your safety, disconnect the power plug from the power outlet if you are not using the scanner for a long period of time.

Preparing the Ink Cartridge

This section describes how to prepare the ink cartridge so that you can use the imprinter to print text or a bitmap on scanned documents.

About the Ink Cartridge

The ink cartridge is not included with the scanner. Purchase an ink cartridge separately, as shown below.

Compatible ink cartridges: Canon ink cartridge PG-50 Black (0616B002) or PG-40 Black (0615B002)

⚠ IMPORTANT

These ink cartridges are available for 5 years after production has stopped.

Setting the Ink Cartridge and Adjusting the Print Position

The ink cartridge needs to be set to print. Set the ink cartridge according to the following procedure. You can adjust the print position to two different levels.

⚠ IMPORTANT

To set the ink cartridge, turn the scanner OFF before removing the Top Cover. After the ink cartridge is set, replace the Top Cover, and then turn the scanner back ON.

1 Remove the Top Cover.

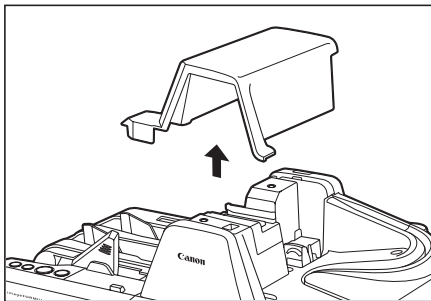

2 Squeeze the Print Position Adjustment Lever, and push it down to the bottom position.

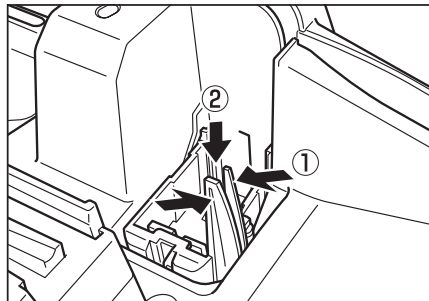

3 Place the ink cartridge shown in the diagram below.

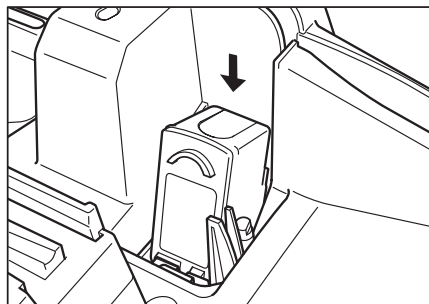

⚠ CAUTION

Do not touch the electrical contact on the carriage. Doing so may cause a malfunction.

📄 NOTE

Do not use more than one cartridge by rotation. If you do so, applications cannot check the ink level precisely.

4 Push down the ink cartridge until it clicks into place.

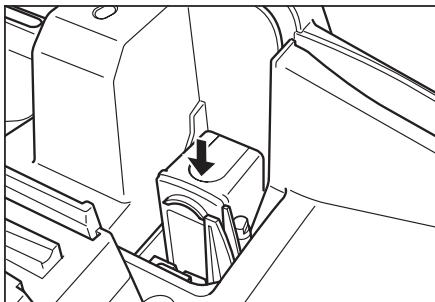

! **IMPORTANT**

Make sure that the ink cartridge is securely in place.

5 Squeeze the Print Position Adjustment Lever and move it to adjust the print position.

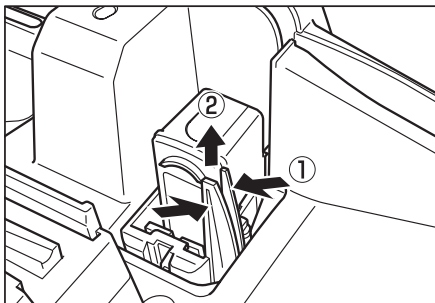

Top:

1.92" (48.8 mm) from the bottom edge of the document

Bottom:

1.17" (29.6 mm) from the bottom edge of the document

6 Carefully replace the Top Cover.

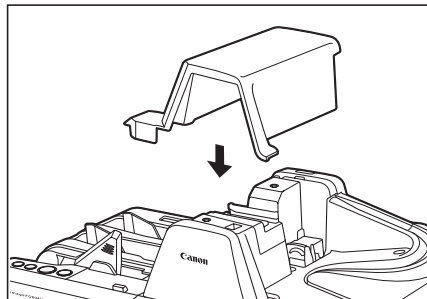

Document Feeding and Scanning

For details on the operations, refer to the Instructions (Electronic Manual) on p. 31 or the Operation & Maintenance Guide (Manual) on p. 5.

Index

A

Adjusting the Print Position..... 13

H

Handling 5

I

Ink Cartridge 13

Installation Location..... 6

Installing the Scanning Utility..... 9

M

Moving the Scanner..... 6

O

Operating Environment..... 9

P

Power Cord..... 7, 11

Power Supply 6

Print Position Adjustment Lever 13

R

Recognizing the scanner 12

S

Scanning Utility..... 9

Setup Disc 7

T

Turning OFF the Power 12

Turning ON the Power..... 11

U

Unpackaging the scanner..... 7

USB Connections 10

USB Connector..... 10



CANON ELECTRONICS INC.

1248, SHIMOKAGEMORI, CHICHIBU-SHI, SAITAMA 369-1892, JAPAN

CANON U.S.A. INC.

ONE CANON PLAZA, LAKE SUCCESS, N.Y. 11042, U.S.A.

CANON CANADA INC.

6390 DIXIE ROAD, MISSISSAUGA, ONTARIO L5T 1P7, CANADA

CANON EUROPA N.V.

BOVENKERKERWEG 59-61, P.O.BOX 2262, 1180 EG AMSTELVEEN, THE NETHERLANDS

CANON LATIN AMERICA, INC.

703 WATERFORD WAY, SUITE 400 MIAMI, FLORIDA 33126, U.S.A.

CANON SINGAPORE PTE. LTD.

1 HARBOUR FRONT AVENUE #04-01, KEPPEL BAY TOWER, SINGAPORE 098632

CANON HONGKONG COMPANY LTD.

19TH FLOOR, THE METROPOLIS TOWER, 10 METROPOLIS DRIVE, HUNGHOM, KOWLOON, HONG KONG.

CANON KOREA BUSINESS SOLUTIONS INC.

168-12 SAMSEONG-DONG, GANGNAM-GU, SEOUL, KOREA